

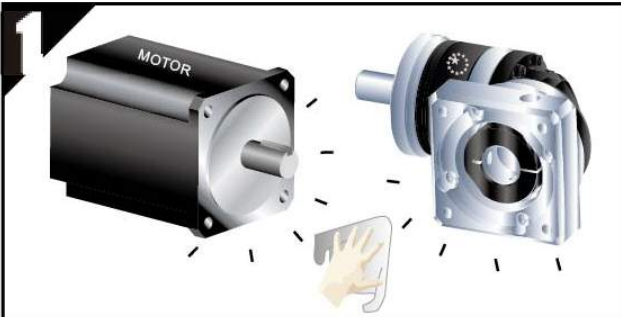

減速機安裝說明書 (PIIR 系列)

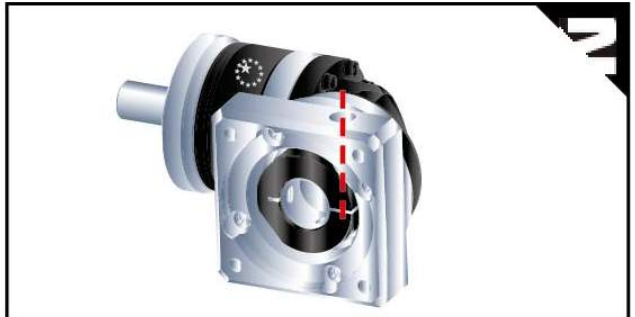

1 確認馬達與減速機規格，並將馬達及減速機之安裝面拭擦乾淨。



2 轉動馬達鎖緊殼，直到鎖緊殼螺絲對準孔蓋孔。

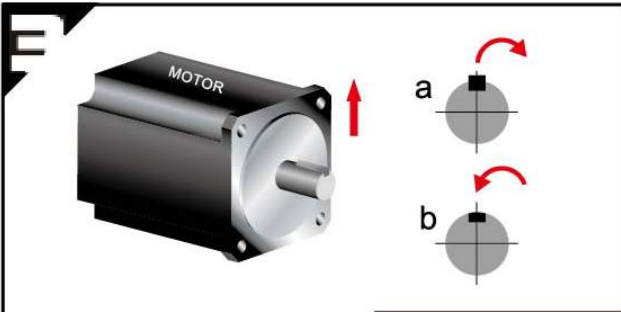

- a. 取下馬達上原先之鍵。
- b. 如有必要，請安裝平衡鍵。



4 確認馬達軸心尺寸。  
(若有必要，裝上軸襯套)

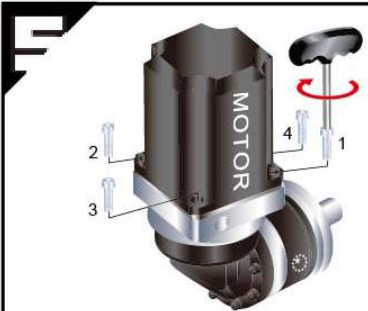

5 直立式地裝入馬達，以螺絲扭力表（表一）建議扭力值之 5%，依 1~4 的順序，用扳手將附墊片之螺絲輕輕鎖上。

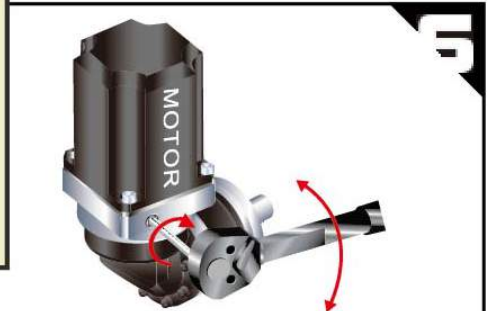

6 將馬達與減速機直立擺設，參照表二建議之扭力值，以扭力扳手將馬達鎖緊殼螺絲鎖緊。

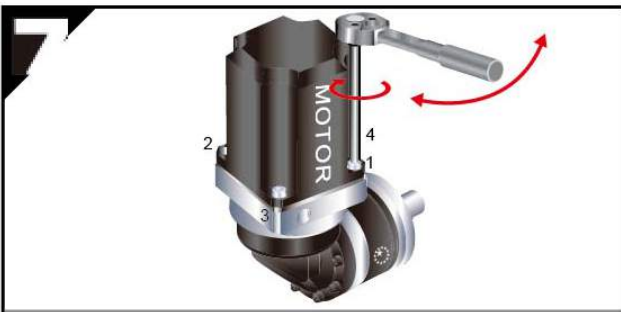

7 將馬達與減速機直立擺設，以螺絲扭力表（表一）建議之扭力值，依 1~4 的順序，用扭力扳手將螺絲鎖緊。



8 裝上蓋孔

**表一 馬達鎖緊螺絲扭力建議表**

螺絲尺寸	六角頭尺寸	強度 8.8 螺絲之鎖緊扭力		強度 10.9 螺絲之鎖緊扭力		強度 12.9 螺絲之鎖緊扭力	
	[mm]	[Nm]	[In-lbs]	[Nm]	[In-lbs]	[Nm]	[In-lbs]
M3 x 0.5P	2.5	1.3	12	1.8	16	2.1	19
M4 x 0.7P	3	3	27	4.1	37	4.9	44
M5 x 0.8P	4	6.1	55	8.2	73	9.8	87
M6 x 1P	5	11	98	14	124	17	151
M8 x 1.25P	6	25	222	34	302	41	364
M10 x 1.5P	8	49	434	67	594	80	709
M12 x 1.75P	10	85	753	116	1028	139	1232
M14 x 2P	12	137	1214	186	1648	223	1976
M16 x 2P	14	210	1860	286	2534	343	3038

**表二 馬達鎖緊穀螺絲扭力建議表**

減速機型號	馬達軸徑	螺絲尺寸	六角頭尺寸	鎖緊扭力	
	[mm]	[mm]	[mm]	[Nm]	[In-lbs]
PE II R050 PA II R042 PG II R040 PN II R017 PS II RA PDR 053	C3 ≤ 8	M5 x 0.8P x 16L	4	9.8	87
	C3 ≤ 11	M5 x 0.8P x 16L	4	9.8	87
	C3 ≤ 14	M5 x 0.8P x 16L	4	9.8	87
PE II R070 PA II R060 PG II R060 PN II R023 PS II RB PDR 064 PLR 070	C3 ≤ 8	M5 x 0.8P x 16L	4	9.8	87
	C3 ≤ 11	M5 x 0.8P x 16L	4	9.8	87
	C3 ≤ 14	M5 x 0.8P x 16L	4	9.8	87
	C3 ≤ 19	M8 x 1.25P x 25L	6	41	364
PE II R090 PA II R090 PG II R080 PN II R034 PS II RC PDR 090 PLR 090	C3 ≤ 14	M5 x 0.8P x 16L	4	9.8	87
	C3 ≤ 19	M8 x 1.25P x 25L	6	41	364
	C3 ≤ 24	M8 x 1.25P x 25L	6	41	364
	C3 ≤ 28	M8 x 1.25P x 25L	6	41	364
PE II R120 PA II R115 PG II R120 PN II R042 PS II RD PDR 110 PLR 120	C3 ≤ 19	M8 x 1.25P x 25L	6	41	364
	C3 ≤ 24	M8 x 1.25P x 25L	6	41	364
	C3 ≤ 28	M8 x 1.25P x 25L	6	41	364
	C3 ≤ 32	M10 x 1.5P x 30L	8	80	709
	C3 ≤ 35	M10 x 1.5P x 30L	8	80	709
PE II R155 PA II R142 PG II R160 PN II R056 PS II RE	C3 ≤ 38	M10 x 1.5P x 30L	8	80	709
	C3 ≤ 19	M8 x 1.25P x 25L	6	41	364
	C3 ≤ 24	M8 x 1.25P x 25L	6	41	364
	C3 ≤ 28	M8 x 1.25P x 25L	6	41	364
	C3 ≤ 32	M10 x 1.5P x 30L	8	80	709
	C3 ≤ 35	M10 x 1.5P x 30L	8	80	709
C3 ≤ 38	M10 x 1.5P x 30L	8	80	709	
C3 ≤ 42	M12 x 1.75P x 35L	10	139	1232	

備註：螺絲鎖緊扭力必須大於上述值。若有需要時，可將鎖緊扭力多增加上述建議值之 20%，以避免打滑。



**APEX DYNAMICS, INC.**

電話：0571-86622450  
 郵箱：info@hzmosen.com

傳真：0571-86625450  
 網址：www.apexms.cn

杭州市濱江區聚源路8號創海基地D503室